



# Bore Hole Jack Installation Instructions



---

## Table of Contents

UNPACKING INSPECTION AND PRECAUTIONS.....	1
TAPE COAT & W1 DOUBLE WRAP INSTALLATION .....	2
STANDARD WARRANTY 2 (PVC ASSEMBLY) .....	4
SEALED WARRANTY 2 (EVACUATIONABLE PVC ASSEMBLY) .....	5
BOTTOM SECTION INSTALLATION.....	7
INTERMEDIATE SECTION INSTALLATION .....	7
TOP SECTION INSTALLATION.....	12
JACK LEVELING INSTRUCTIONS.....	13
ONE PIECE JACK INSTALLATION AND PRECAUTIONS .....	14
PRESSURIZED EVACUATION SYSTEM INSTRUCTIONS FOR SEALED WARRANTY 2.....	14
MONITORING SYSTEM INSTRUCTIONS FOR STANDARD WARRANTY 2 & WARRANTY 3 .....	15
SEAL REPLACEMENT INSTRUCTIONS.....	15

---

## **UNPACKING INSPECTION AND SAFETY PRECAUTIONS**

1. If your jack has the “W2” rigid PVC option, where the PVC is installed to the jack, be sure that the PVC and its fastening pins are intact. If the pins are damaged or the PVC is broken, you must address the damage with the shipper and call DLM before attempting to install. Broken pins can result in the PVC falling during assembly and cause injury. (See lower left picture) 
2. Make sure that all shipping material is in place at the bottom of the jack sections. If the shipping material is missing or looks like it was damaged, check the plunger ends for any type of damage. (See upper left picture) Any damage (ding or scratch) may result in poor sealing surface or bad parts. Do not remove the tin wrapping unless it has been damaged beyond repair. This will help protect the tape coat while lowering jack into hole. Any damages must be addressed with the shipper and a call must be made to D.L. Martin to be sure it can be used.
3. Do not hit or drop the cylinder couplings. A hit to the coupling will result in the coupling becoming egg shaped making it very difficult to take off. (See upper right picture)
4. Check to make sure that you remove the hardware kit and install the bleeder valve before the jack is pressurized. The bleeder hole (located on the cylinder) has a small cap installed in it; this cap keeps dirt out during shipping. This cap is **not** designed to withstand hydraulic pressure.
5. After jack is assembled and before pressurizing, be sure to check that the retaining ring is in place to hold sleeve/seal packing in place. The sleeve/seal kit could potentially rupture and cause injury. (See lower right picture) 

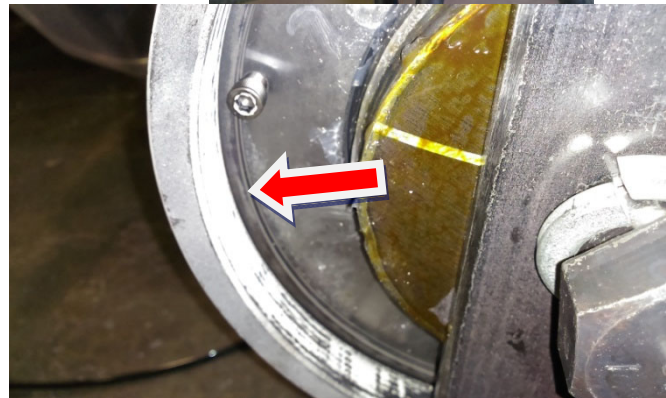
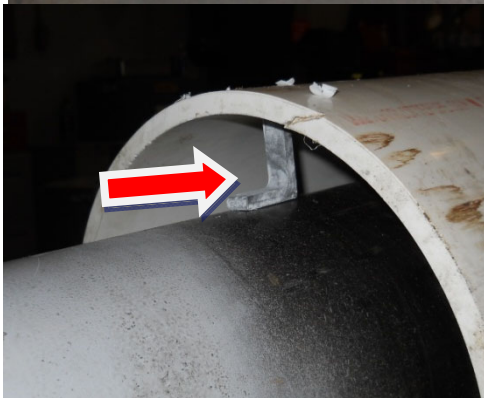

## TAPECOAT & W1 DOUBLE WRAP TAPECOAT INSTALLATION

**NOTE: Apply to each cylinder joint after assembly**

1. Clean exposed metal of joint with non-petroleum solvent and wire brush.
2. Remove moisture from cylinder surface.
3. Spiral wrap 2 inch Tape coat with 1 inch overlap over the entire coupling. Overlap factory applied Tape coat by 3 inches.
4. If jack is a warranty 1 jack (double wrap tape coat), spiral wrap 2 inch Tape coat a second time to provide a second layer of protection. (See pictures below for examples.)
5. Repeat these steps for each cylinder joint.

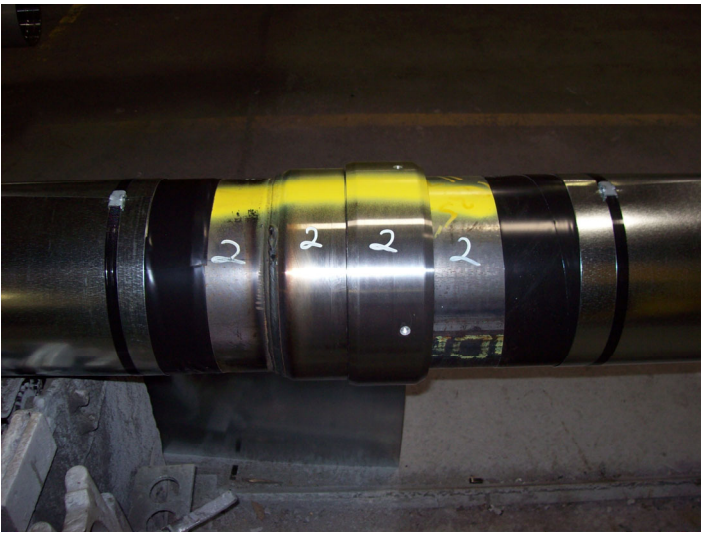

## STANDARD WARRANTY 2 (W2 PVC ASSEMBLY)

**NOTE: These instructions are for the connection of the PVC joint not the metal cylinder joint, if your jack does not have this option, proceed to BOTTOM SECTION INSTALLATION.**

### ITEMS REQUIRED:

- Sandpaper (120 grit or higher)
- Cleaning solution (non-flammable and non-petroleum based)
- 5/16" Nut driver or 1/4" ratchet and 5/16" socket
- RTV Silicone Gasket Maker (Perfecta Seal brand provided)

### PROCEDURE:

1. After assembling the plunger and cylinder sections, apply tape coat to cylinder joints as specified previously.
2. Sand smooth any rough edges, grooves, or scratches on OD of the upper and lower PVC pipe. Sand 10 inches from the edge on both sections of PVC. Sand around PVC, not up and down. Upon completion of sanding PVC clean this area well with a cleaner that does not leave any oily residue.
3. Loosen stainless steel clamps on rubber couplings and lower the bottom rubber coupling onto PVC. Slowly work the PVC coupling down over the open area in the PVC (approx. 12.75" gap) and onto the lower PVC pipe. Mark the lower section of the PVC pipe so that the PVC coupling covers the upper & lower PVC pipe equally. The PVC is pinned to the cylinder; **do not** move the PVC, only the couplings.
4. Apply a film of silicone sealant to the PVC pipe and PVC coupling at each end of the coupling where the rubber coupling will slide into place (See Picture Below for Example).
5. Slide rubber couplings into place and place the stainless steel clamps on rubber coupling (rubber couplings have indentations for location of clamps) and tighten using the Nut driver or ratchet and socket, max torque is 150 in/lbs or 12.5 ft/lbs.
6. Repeat steps 1-5 at each joint as jack is assembled.

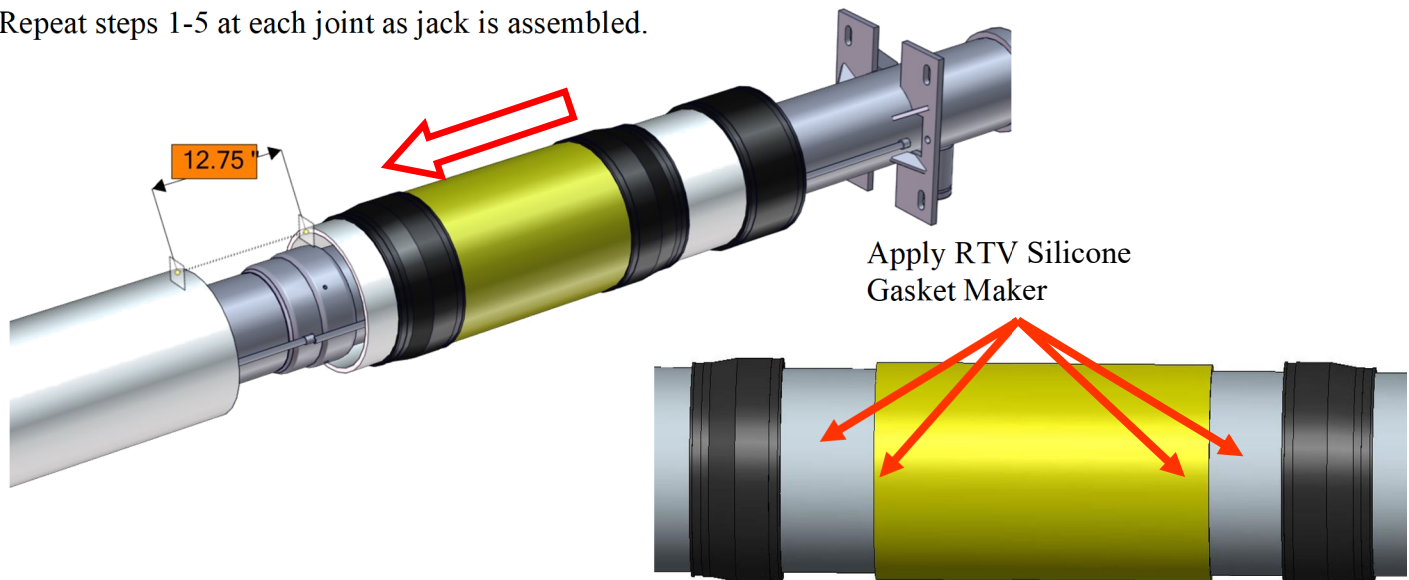

# **SEALED WARRANTY 2 (W2S EVACUATIONABLE PVC ASSEMBLY)**

**NOTE: These instructions are for the connection of the PVC joint not the metal cylinder joint, if your jack does not have this option, proceed to BOTTOM SECTION INSTALLATION.**

## ITEMS REQUIRED:

- Sandpaper (120 grit or higher)
- Cleaning solution (non - flammable)
- Petroleum jelly
- Duct tape or tie straps
- Thread sealant

## PROCEDURE:

1. Install and securely clamp bottom PVC section (with end cap), to prevent section from falling in hole.
2. Sand smooth any rough edges, grooves, or scratches on OD, 12" from end of intermediate section. Sand around PVC not up and down. Clean this area well.
3. Make sure that the 3/4" x 15° chamfer is on the top PVC section that inserts into the sealing flange (shown in fig. 2).
4. Mix half of one tube of two parts Loctite epoxy per coupling and apply with trowel to 3-5 inches of the O.D. of PVC pipe end. Slide PVC pipes into couplings, twisting approx. 1/4 turn as you slide it in place. Let assembly set a minimum of 4 hours or until epoxy sets before proceeding. (Read Manufacturer's Instructions for cure time per a given temperature.) Caution: If epoxy is not allowed to set, pipe could fall making it potentially fatal or costly.
5. Next lower the PVC into the hole and clamp again as needed. Repeat steps 2 - 4 until the PVC joints are fully assembled.
6. Duct tape or tie wrap small 1/4" O.D. PVC Evacuation Tube (shown in fig. 4) to bottom jack section, making sure the small PVC is at least 3" below the bottom cylinder section.
7. Lower cylinder into PVC casing and clamp as necessary to prevent falling.
8. Install intermediate cylinder section to bottom cylinder section using standard jack assembly instructions.
9. Connect next 1/4" O.D. section of PVC to piece that is attached to the bottom section with supplied glue and couplings. Mix small amounts of glue to join the 1/4" O.D. sections. Let set ten minutes or until the epoxy hardens. Lower jack and repeat steps until all sections are assembled.
10. Thread 15" x 1/4" O.D. PVC section into the PVC sealing flange on the top cylinder section using thread sealant. Then glue to existing 1/4" O.D. PVC.
11. Install large o-rings into sealing flange (shown in fig. 1) and lube the o-rings liberally with petroleum jelly or Dow Corning 111 that is supplied with joint kit.

12. Lower jack slowly until the jack is fully engaged into the PVC casing, making sure the PVC is bottomed out in the sealing flange. Drill 1/4" holes into PVC through the holes in sealing flange. Next install the specially machined Allen head bolts with the sealing washers provided into the holes in the sealing flange. (shown in fig. 3)
13. After jack is in position, install pipe nipples, pop-off valve, couplings, fitting reducer, and air valve to the top of the flange using thread sealant as needed. The pipe nipples will protrude through the mounting feet. Be sure to install the air inlet to the side opposite the evacuation tube (shown in fig. 3).
14. Attach warning label to top of cylinder under head area where it can be seen easily.

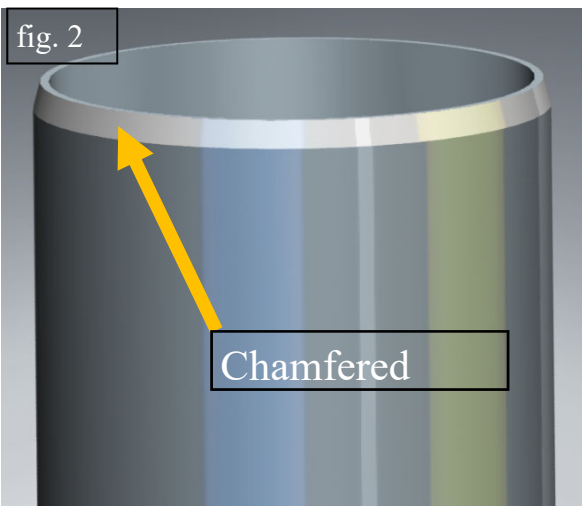
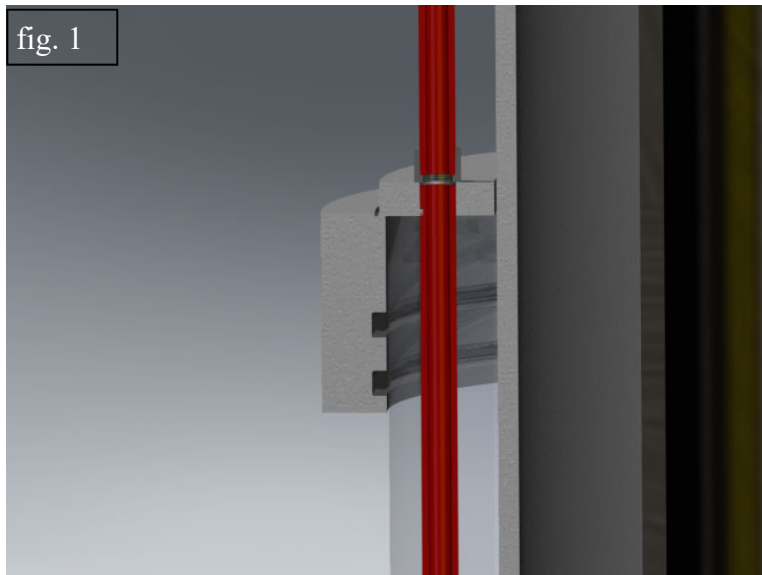

Safety Pop-off Valve

PVC

Evacuation Tube

Allen head bolts w/ stat-o-seal sealing washers, 6 plcs.

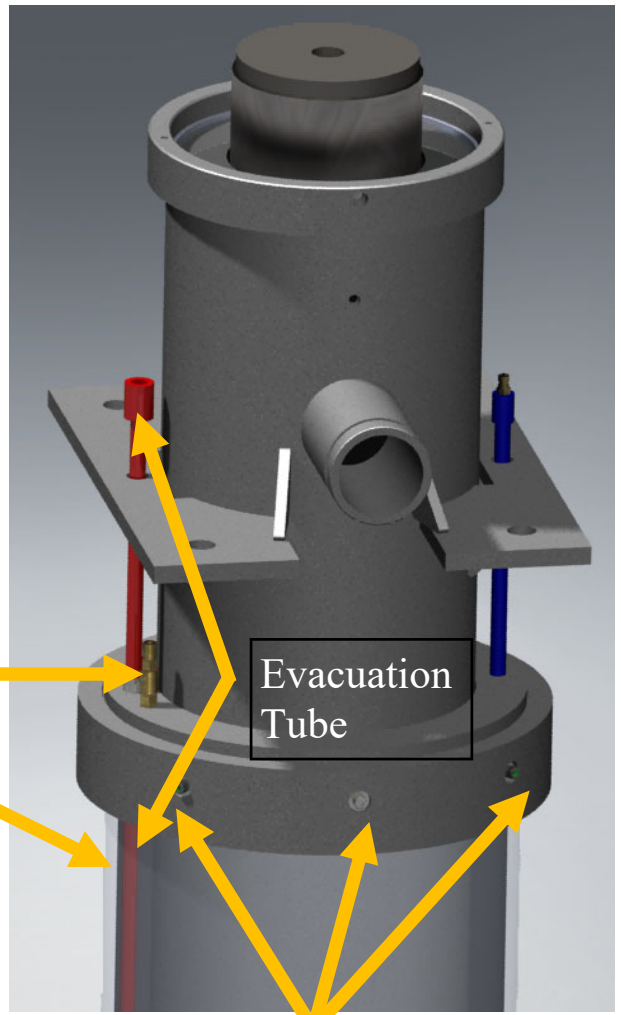

## **BOTTOM SECTION INSTALLATION**



Before lifting bottom jack section, make sure the ship cap is securely fastened to the cylinder section. If the ship cap is not on correctly, jack section may fall during installation causing personal injury or death.

1. Attach hoist equipment to the ship cap through the eyebolt of the bottom section. Move bottom section over to proper position and lower section into hole. Lower bottom jack section into hole and place clamps onto cylinder at desired height.



Before going any further you should make sure that the jack section will not slip through the clamps when tension is released from the hoist. Lower section until clamps rest on pit floor, next lower hoisting chain until there is no tension in the chain. This will test to see if the grip on the cylinder from the clamps is satisfactory. If you need to adjust the tightness of the clamps do so and repeat test.

2. After the bottom section is properly clamped and resting on the pit floor, remove female coupling with spanner wrench or strap wrench to expose plunger for installation of the next jack section. The female coupling is removed in a counter clockwise rotation. When removing the female coupling secure the eyebolt with a bar. This will prevent the eyebolt from turning with the female coupling.

NOTE: Do not unscrew top ship cap at eyebolt because it may jamb ship cap, damage plunger or plunger coupling.



Since dust and debris can fall into the inside of the jack section after the ship cap is removed; protect the jack section by covering the opening. By keeping the inside sections clean it will help keep problems from arising in the future.



3. Once the ship cap is removed, screw the female coupling back on the male coupling so that it can be installed onto the upper section after plunger connection. With the eyebolt still attached securely to the plunger, raise plunger out of the cylinder section about 2' to 3'. Once the plunger is at this height, use clamps (Do not mar plunger surface) to hold it in that position. NOTE: Keep items away from the plunger that might damage the surface finish of the plunger. Also keep the hole between the plunger and cylinder covered at all times. Tie clean rags around the plunger to keep items from falling down inside the sections.



Before going any further you should make sure that the plunger will not slip through the clamps when tension is released from the hoist. Then lower plunger until clamps rest on cylinder. Next lower hoisting chain until there is no tension in the chain. This will test to see if the grip on the plunger from the clamps is satisfactory. If you need to adjust the tightness of the clamps do so and repeat test.

4. Lower hoisting chains and remove chains from the plunger eyebolt ship cap. Once the ship cap is disconnected; unscrew the eyebolt ship cap from the plunger.

## **INTERMEDIATE SECTION INSTALLATION**

**NOTE: Follow the next steps if your jack assembly is a 3 piece or more. If the jack assembly is only a 2 piece, move ahead to TOP SECTION INSTALLATION.**



Before lifting intermediate jack section make sure that the ship cap is securely fastened to the cylinder section. If ship cap is not on correctly jack section may fall during installation causing personal injury or death.

1. Attach hoist equipment to the ship cap through the eyebolt on intermediate jack section. (If there are multiple intermediate sections make sure that the black stenciled numbers on the mating ends match. If there is “#1” stenciled on the top end of a section look for a section that “#1” is stenciled on the bottom end. The numbers need to match 1 to1, 2 to 2, and 3 to 3 etc.)

NOTE: with this assembly you will need an item on your hoist setup that will allow the jack section to spin freely and not get tangled. (Ex. turnbuckle). This is needed because the assembly process will be spinning the upper plunger onto the stationary bottom plunger.

2. Hoist jack section to proper height clearing the bottom section, align upper section over bottom section, then lower upper section to working height directly above the bottom jack section.



Upper section must be plumb and directly over the bottom section to prevent installation problems and to prevent damage to the threads on plungers.

3. Remove bottom protective coating off the intermediate section. (Note: Split rings are stored under the mesh netting beneath the protective coating. Use caution when removing coating to prevent split rings from dropping into the lower cylinder barrel or borehole.) Clean plunger area of any foreign substance with some type of solvent. Inspect plunger for dings, nicks, or scrapes. If there are any kinds of blemishes, please contact D.L. Martin at the number printed on the sticker on the jack assembly. Carefully pull plumb line from upper jack section. Disconnect plumb line from anchor (small PVC loop, see picture on previous page) in lower section and inspect for kinks, bends or other damage. Remove suspect areas and then splice the two plumb line ends together using eye twist method. Make at least five twists. Feed extra length into bottom section.

4. Remove split rings from mesh package on cylinder. Make sure rings are not bent or twisted. After packaging is removed unscrew the female coupling that was reattached in (step # 3 Bottom section installation) of the Bottom section Assembly, and slide it up over the bottom of the upper section. (Threads should be pointing down.) Slide coupling up over welded shoulder on the upper cylinder section. Place split rings on lip and then lower the female coupling over the split rings. (If split rings seem to have a different radius as the cylinder, stand the ring on its end and give the other end a tap with a hammer. This will give some form back to the split rings if needed.) The female coupling will be held there while the assembly is being lowered into place.

5. Make sure o-rings and bearing are located in the bottom jack section. Inspect the plunger and cylinder o-ring for scrapes, nicks, or blemishes. The cylinder o-ring is placed in the groove located just inside the top of the cylinder. Clean & inspect both the female and male threads on the plunger sections. If thread damage is detected, repair threads and repeat cleaning. Threads must be free of debris or damage for proper installation.





6. Apply anti-seize (Loctite C5-A copper based) generously to both the male & female threads. Do not apply anti-seize to o-ring. Apply an o-ring safe silicone (Dow Corning 111) to the o-rings of the plunger and cylinder. Use a generous amount of silicone on o-rings, o-ring grooves, and immediate areas.



Make sure that o-ring is seated properly in its groove to prevent damage at assembly.

7. Apply (Loctite 592) Pipe Thread Sealant very sparingly to the tapered mating surface of the male plunger coupling. Use only enough compound to form a gasket between the two surfaces of the male and female plunger sections. Too much compound will cause the scribe marks not to align properly.



When screwing plunger sections together pay special attention to the top ship cap. Make certain that the ship cap is not unscrewing from elevated jack section. If jack ship cap comes loose the section will fall causing damage to the jack assembly and probable personal injury or death.

8. Carefully and slowly lower the upper jack section so the female and male plunger couplings engage. Do not allow chain hoist to become slack.

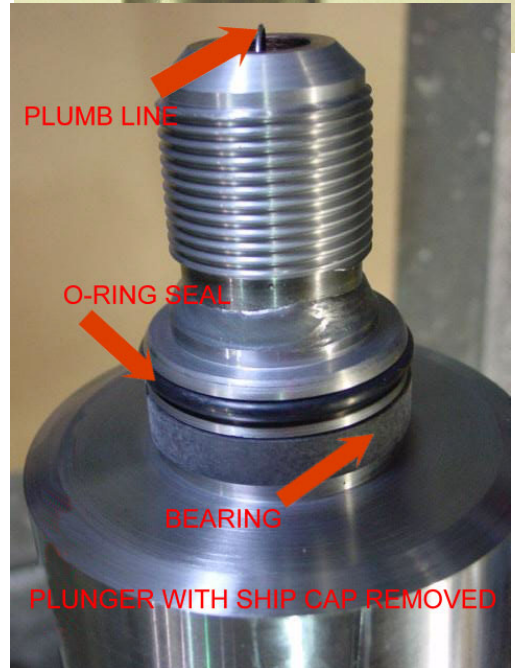
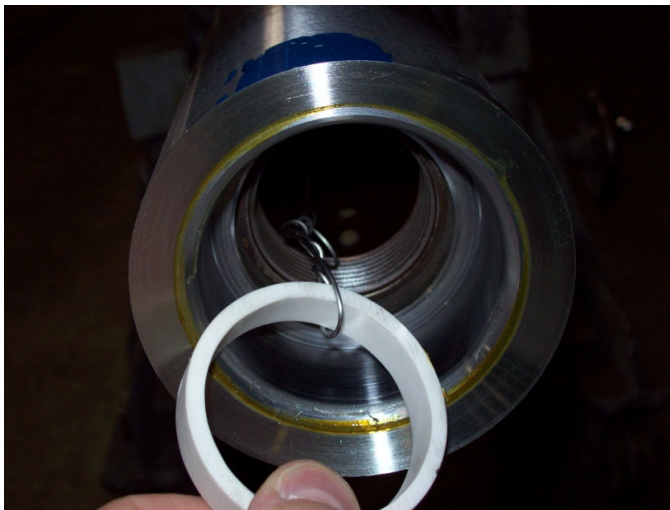

9. Start spinning the upper section in a clockwise rotation. Making sure that the turnbuckle is spinning with the upper jack section and the chain and hoist are not getting tangled.



If any type of bind is felt STOP immediately. If you do not stop you risk the chance of damaging the threads. Unscrew the jack assembly, inspect the threads, and repair if necessary.

10. After the first thread is engaged stop and lock the turnbuckle.
11. Carefully turn upper plunger section by hand until the gap between the 2 plungers is about 1/16th of an inch; and, then raise both plunger sections up approximately 1/4th of an inch.
12. Keep turning top plunger section by hand until the scribe marks cross. Then use a strap wrench to align marks perfectly. NOTE: If wrench slips on plunger a piece of sand paper or rubber will help get better grip on the plunger surface.
13. Make sure there is no gap between the sections. By using 2 strap wrenches against each other you can eliminate any gap that could possibly cause damage to the seals.



If any type of bind is felt on any of the installation, STOP immediately. If you do not stop you risk the chance of damaging the threads. Unscrew the jack assembly, inspect the threads, and repair if necessary.

14. With rags still in place clean excess Loctite from the joint. If there is no lip experienced over the joint (fingernail should not catch on plunger joint), sanding is not necessary. Take emery cloth or a Scotch-Brite pad and blend in the area 6 to 12 inches above and below the joint as required.
15. If a lip is experienced remove only the high spots with a fine-tooth mill file. Do not cause hour glass shape. When sanding sections, while sanding horizontally, work up and down the plunger approximately 6-12 inches above and below the joint where the high spots are experienced. File perpendicular (horizontally) to the plunger axis. After the joint is even go over the area with a piece of emery cloth or a scotch-brite pad.
16. After the sections are together raise the upper jack section and remove the wood clamps from around the bottom plunger.
17. Check o-rings and the threads on the cylinders for nicks, scratches, or chips. Clean threads on the cylinder to make sure they are free of debris.



Check and rewind turnbuckle if necessary so the upper jack sections do not become unfastened.

18. Apply an o-ring safe silicone (Dow Corning 111) to the o-ring inside the cylinder. Use a generous amount of silicone on o-ring, o-ring groove, and immediate area. Apply anti-seize (Loctite C5-A Copper Based) sparingly to both the male & female threads. The anti-seize could possibly cause binding on the cylinder threads. Also use anti-seize on contact areas. Be sure and check o-ring



contact area on male cylinder machined surface for nicks or scratches that may damage o-ring. If any are found, fix immediately with emery cloth or lightly file if necessary and then smooth with emery cloth.

19. Check the split rings installed in step #4. They should be installed between the coupling and the shoulder welded to the cylinder. Push down on the coupling until the rings bottom out on the shoulder.
20. Measure the distance “X” between the top of the male coupling and the lower cylinder. Mark the distance on the upper cylinder so you will have an idea how close the cylinders are from touching when assembling. See drawing. This will ensure complete engagement.

21. Lower the upper cylinder into the male cylinder coupling. Make sure the o-ring does not get pinched. Lower upper cylinder until cylinders touch. The distance marked on the cylinder in step # 20 should verify that the cylinders are touching. The upper cylinder may need to be shifted a little in order for the cylinder to be lowered fully into place.



If any type of bind is felt on any of the installation, STOP immediately. Do not force sections together.

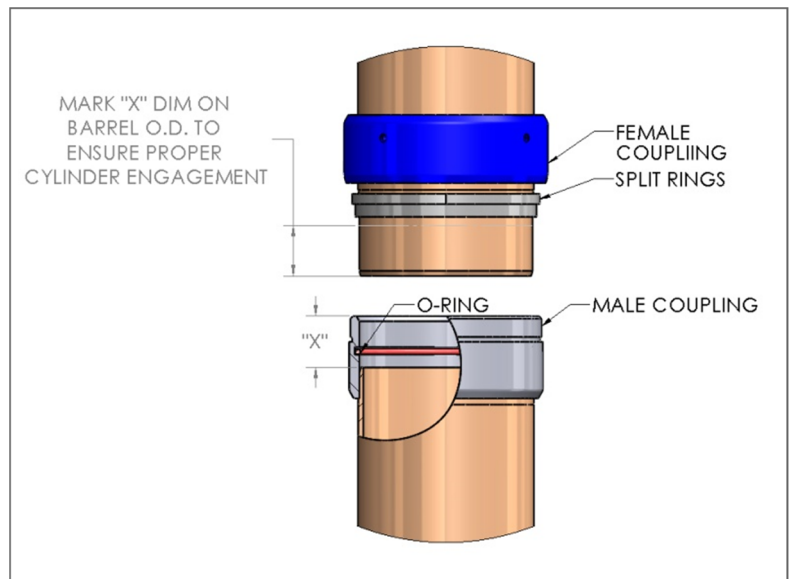

Possible reasons why the cylinders will not go together properly:

- The eyebolt ship-cap on the plunger is partially unscrewed. The eyebolt ship-cap needs to be screwed down all the way on the upper plunger.
- Plunger is not completely down on its centering pin or guides. Move plunger around to make sure it is in its proper position.

22. Spin female coupling on by hand as far as possible. To fully tighten use a spanner wrench or strap wrench. It is possible to see a thread at the bottom of the female coupling still exposed.



This threaded coupling does not require welding. If welding is done to this joint, coupling must be welded on both ends to ensure a sealed joint. The o-ring must also be removed.

23. If there is another intermediate section repeat these steps.

# TOP SECTION INSTALLATION

1. Top section does not have an eyebolt ship-cap. The mounting plate must be used to pick up the top section.



Shipping bracket that attaches plunger to cylinder is intended to prevent plunger falling out of cylinder. Top bracket is not designed to hold weight of entire plunger after sections are assembled. Also check that sleeve retaining ring is in place before pressurizing.

2. Repeat steps used for intermediate section assembly.
3. The following shows the proper installation of the field hardware kit for mounting the jack and spring buffers to the pit channels and pit floor.

ITEM #	PART NAME	QTY
2	HEX NUT .750-10	16
3	FLAT WASHER .750	12
4	LOCK WASHER .750	8
5	ANCHOR STUD .500-13 X 3.75 & NUT .500	4
7	PIT CHANNELS	2
8	JACK	1
9	SPRING BUFFERS	2
12	HEX BOLT .625-11 X 2.25	4
13	HEX NUT .625-11	4
14	FLAT WASHER .625	8
15	LOCK WASHER .625	4
18	SUPPORT PLATE	4
21	ALL THREAD .750-10 X 6.00	4

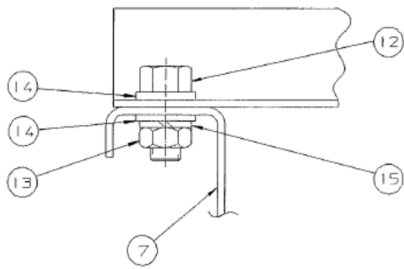
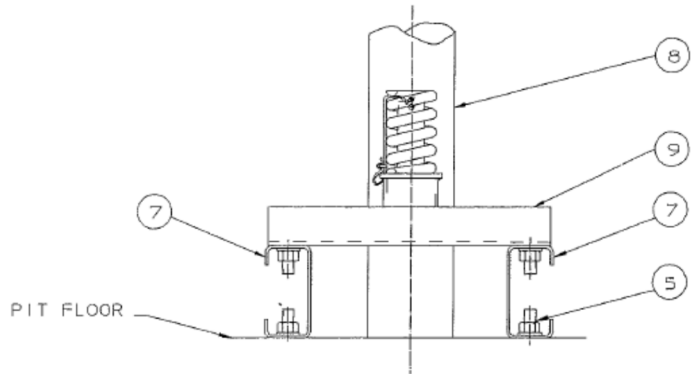

SECTION B-B

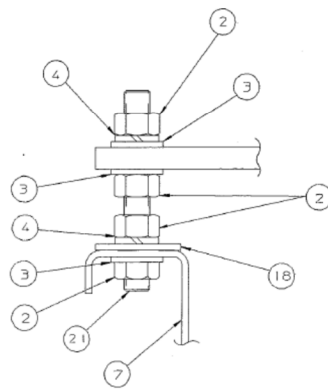

SECTION A-A

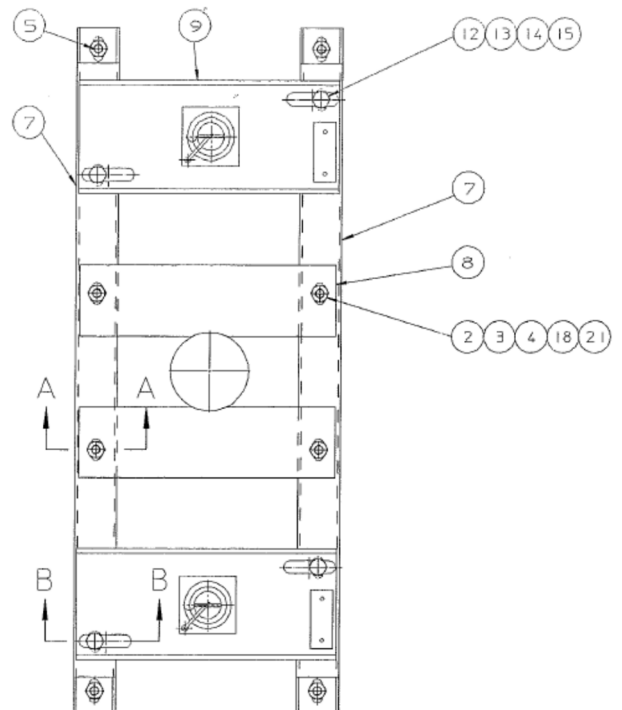

# JACK LEVELING INSTRUCTIONS

## ITEMS REQUIRED:

- Spool of string
- C-clamps
- 2 x 4 Board
- Spool of steel tie wire
- Drill and drill bit

## PROCEDURE:

1. Make sure plunger is setting on pin at bottom of cylinder. (This pin centers plunger in cylinder)
2. Tie a string to the guide rails above the plunger, and mark the centerline between the rails.
3. Measure any offset side to side or front to rear between the centerline string and the center of the plunger.
4. Install a target board at the top of the guide rails. Hold it in place with c-clamps.
5. Drill hole in target board to represent centerline plus offset measured.
6. Hang tie wire from target hole to plunger and pull tight.
7. Splice plumb wire from plunger to target wire and make sure wires are straight and tight.
8. Adjust the four leveling bolts until jack is plumb. Jack is plumb when plumb wire is centered in the hole at the top of the plunger and touching the rail center line string

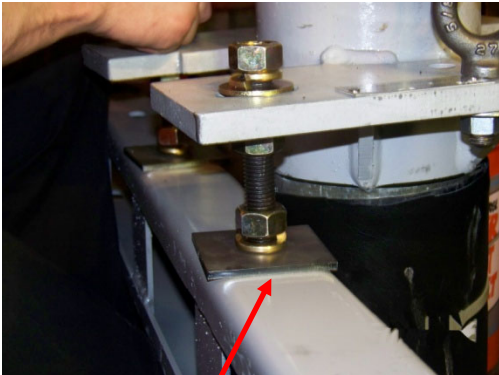

Jack Leveling Bolts

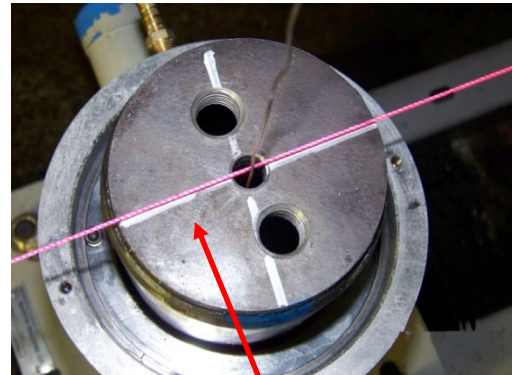

Rail Centerline String and Plumb Wire



Target Board



portable pump and fill jack through oil inlet line.

NOTE: If piston rub is encountered, follow the steps below to fix.

- Block car up.
- Separate piston from platen plate by removing attaching bolts from piston.
- Rotate piston 90 degrees in any direction. Reattach piston to platen plate.
- Run car up and down several times. Listen for rubbing noise.
- If noise is still heard, repeat steps. Rotate piston another 90 degrees in same direction as previous step.
- If noise is still heard repeat steps once more. At this point if noise is still heard such as bumping or banging the jack may be too far out of plumb and the jack leveling procedure will need to be redone.

## **ONE PIECE JACK INSTALLATION AND PRECAUTIONS**

1. See “Top Section Installation” for installation details.



In the event that an extra long one-piece jack is used, (usually over 30') remove the stabilizing saddle from inside the jack. The cable attached to it will exit the inlet and wrap around the cylinder above the mounting feet.

## **PRESSURIZED EVACUATION SYSTEM INSTRUCTIONS FOR SEALED WARRANTY 2**

### ITEMS REQUIRED:

- Calibrated pressure regulator preset at 7psi (WARNING: anything above 10psi can shatter the PVC and seriously injure)
- Fitting for evacuation tube and a length of hose with hose clamp
- Small bucket for evacuated fluids

### PROCEDURE:

1. Be sure the air inlet side is screwed into the correct side. The evacuation tube is located under the side with the half coupling welded to sealing flange. (See fig. 3 on page 6 above for details)
2. Connect air hose to regulator and then to the fitting on the end of nipple.
3. Continue until no fluid is seen exiting the hose.

# **MONITORING SYSTEM INSTRUCTIONS FOR STANDARD WARRANTY 2 & WARRANTY 3**

## ITEMS REQUIRED:

- Length of cord or string, a few feet longer than the rise of the system, with a small weight attached, small enough to fit into small PVC pipe.

## PROCEDURE:

1. Take cap off PVC tube (sight tube) that is located by the mounting feet of jack assy.
2. With the opposite end of the cord or string secured (so that the cord or string cannot be dropped in tube) slowly lower the weight in to the pipe. Allow it to be lowered until the weight cannot be felt. When the string goes slack the weight is at the bottom of the PVC.
3. Pull the weight back up through the tube. While pulling the weight back up inspect the cord or string for liquid.
4. If the cord is wet measure the distance from the weight. This measurement will be the depth of the fluid between the PVC and the metal cylinder.

## **SEAL REPLACEMENT INSTRUCTIONS**

### TOOLS REQUIRED:

- Container for hydraulic fluid
- Clean Rags and protective covers as required
- Prying tool – no sharp edges
- Seal housing puller – contact D.L. Martin Co. for information on pullers
- Blocking pipe or timbers
- Hammer
- Sandpaper (very fine)
- Two straight edge screwdrivers
- Allen wrench for shoulder bolts

### JOBSITE PREPARATION:



Use safety equipment, safety barriers and protective clothing while working on equipment. Failure to use required safety apparatus can result in injury or death.

1. Run car above bottom floor to gain access to the pit. Run car from the machine room or have a helper run it on hand control.
2. Run car and inspect piston for the following:
  - Pits or corrosion
  - Piston joint for uneven mating: Blend joint with emery cloth before changing seal.
  - Sharp edges at the top of piston: Remove with sandpaper or file before taking jack apart.

- Place blocking pipes or timbers, and block car into position.
- Remove bolster connection between platen plate and piston and then lower plunger until it bottoms out.
- Close all safety valves. Open and tag mainline disconnect. Turn pit switch OFF.
- Drain oil from the top of the packing through the oil return port. Clean remaining oil and dirt from top of packing with rags.

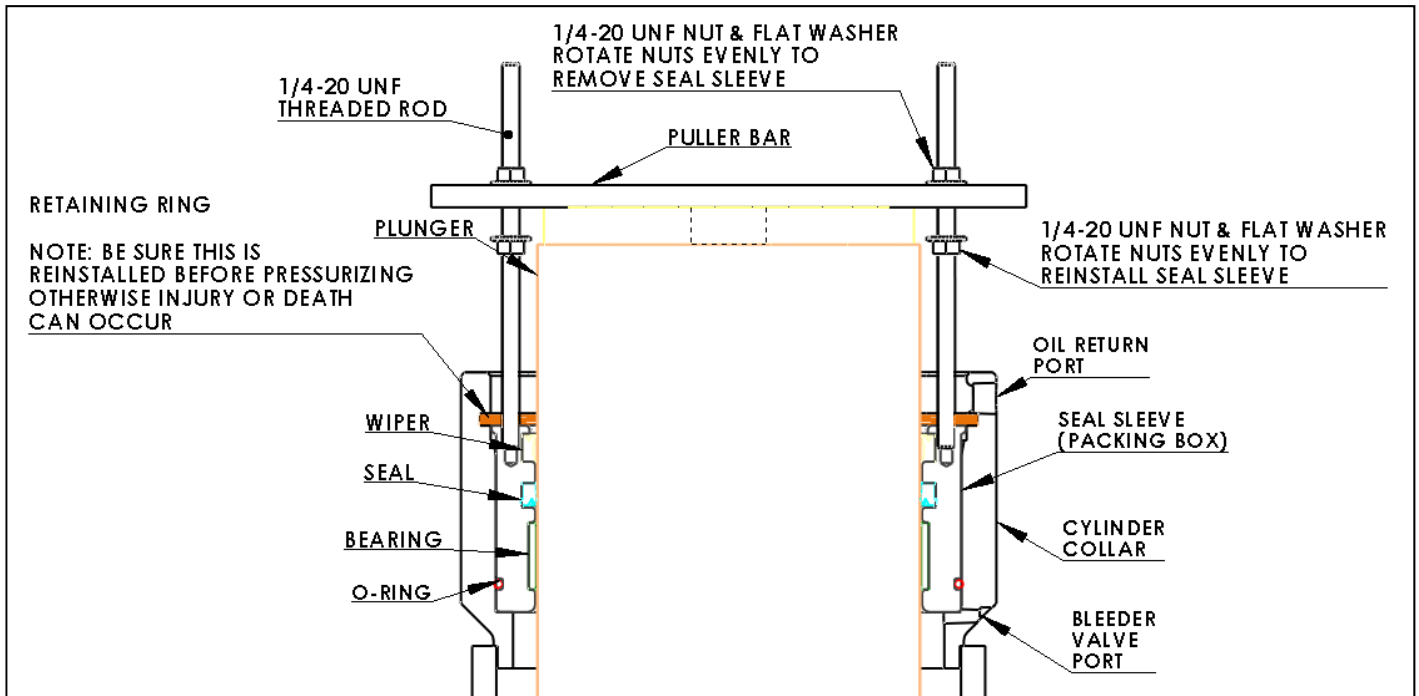

#### PACKING SLEEVE REMOVAL:

- Open bleeder valve and drain oil into container and leave open until packing has been replaced. Be careful not to drop bleeder into jack hole.
- Remove two allen bolts from top of packing sleeve.
- Gently pry the notched end of retaining ring out of the cylinder collar groove with one of the screwdrivers while working the end upwards with the second screwdriver. Once retaining ring has been started out of the groove it should slide out easily by turning and pulling it out.



Note: Do not use excess force on retaining ring as this will cause it to stretch and require replacement.

- Clean and inspect top of packing sleeve. Note the kind of debris (steel or dirt). Steel particles indicate rubbing that needs to be corrected.
- Inspect threaded holes and clean with tap if needed.
- Screw threaded rod into tapped holes in packing sleeve.
- Place puller bar across top of plunger and over threaded rod. Install flat washers and nuts and snug,



keeping puller bar level with sleeve.

8. Remove packing sleeve by evenly tightening the nuts.
9. Once sleeve is removed completely, remove o-ring, wiper, seal and bearing. Inspect seal for cuts and softness. Also check sleeve for metal to metal contact.
10. Clean packing sleeve and inside of cylinder thoroughly with mineral spirits or equivalent.
11. Install new bearing, seal, wiper and o-ring in proper orientations as shown.
12. Check used o-ring for damage such as cuts or nicks, and repair mating surface inside of cylinder as needed with emery cloth and clean thoroughly.

Common problems that cause cuts or nicks to seals and sleeve:

- Pits or corrosion on the plunger. Sand lightly with a very fine emery cloth when jack is returned to service, if deep pits are found call for assistance.
- Uneven plunger joint. Take an emery cloth or Scotch-Brite pad and using an around circumference motion (never up and down) blend area 6 to 12 inches above and below joint.
- Steel chips caught in the sleeve or on plunger surface. Clean all parts and thoroughly wipe down plunger when jack is returned to service.
- Steel chips in oil line from construction that have worked their way into the jack. Inspect oil line and clean or repair as necessary.

#### PACKING SLEEVE INSTALLATION:

1. If sleeve puller was removed, reinstall and tighten nuts on both sides of puller.
2. Position seals over plunger. Push down on the puller slowly and evenly until sleeve bottoms out.
3. Install retaining ring. Spread bottom wrap of retaining ring and insert into groove and work ring around until fully inserted.
4. Install and snug allen bolts.
5. Close bleed valve.

## TESTING JACK:

1. Make sure elevator is on hand control.
2. Open all safety valves.
3. Close mainline disconnect and set pit switch to ON.
4. Open bleeder valve about one-half turn.
5. Jog car on hand control to pre-bleed air from the jack. Close valve when all air is removed.
6. Raise jack to platen plate and install.
7. Remove blocking from car.
8. Bleed jack after running car through entire hoistway.
9. Check plunger for even oil film while running car through entire hoistway. Remove any debris sticking to the plunger. If jack is a multi-piece, check plunger for smooth joints and blend as necessary.
10. Set pit switch to OFF.
11. Clean oil spills and empty overflow bucket. Make sure overflow hose will drain properly into bucket.
12. Set pit switch to ON. Car can now be set to automatic.

If there are any questions, problems, or concerns please contact D.L. Martin (717) 328-2141. Please record the serial number (See attached photo for location) or the sales order number stenciled on the side of the jack and on the mounting plate prior to making your call in case the D. L. Martin representative needs this number.

